

### BILL OF MATERIAL

SEQ NO	QTY	PC MARK	DESCRIPTION	LENGTH	REMARKS	WEIGHT TOTAL	ADVANCE MILL #
4	ONE	4020HR1	HANDRAIL			316	
	1		4020HR1 PIPE 1/2 STD	15 27/16	A53	41	
	3		hss531 PIPE 1 1/2 STD	3 9 5/16	A53	31	
	1		hss533 PIPE 1 1/2 STD	3 5 11/16	A53	9	
	1		hss455 PIPE 1 1/2 STD	3 4	A53	9	
	1		hss466 PIPE 1 1/2 STD	3 3 5/8	A53	9	
	3		hss534 PIPE 1 1/2 STD	3 3 1/8	A53	27	
	1		hss532 PIPE 1 1/2 STD	0 4 1/8	A53	1	
	1		hss464 PIPE 1 1/2 STD	0 2 15/16	A53	1	
	1		hss578 PIPE 1 1/4 STD	19 5 9/16	A53	44	
	1		hss572 PIPE 1 STD	0 3	A53	0	
	1		rb56 RB 3/4	2 7 13/16	A36	4	
	35		rb54 RB 3/4	2 7 1/2	A36	138	
	4		rb52 RB 1/2	0 4 5/8	A36	1	
	1		rb55 RB 1/2	0 4 5/8	A36	0	

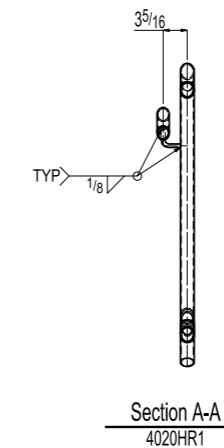
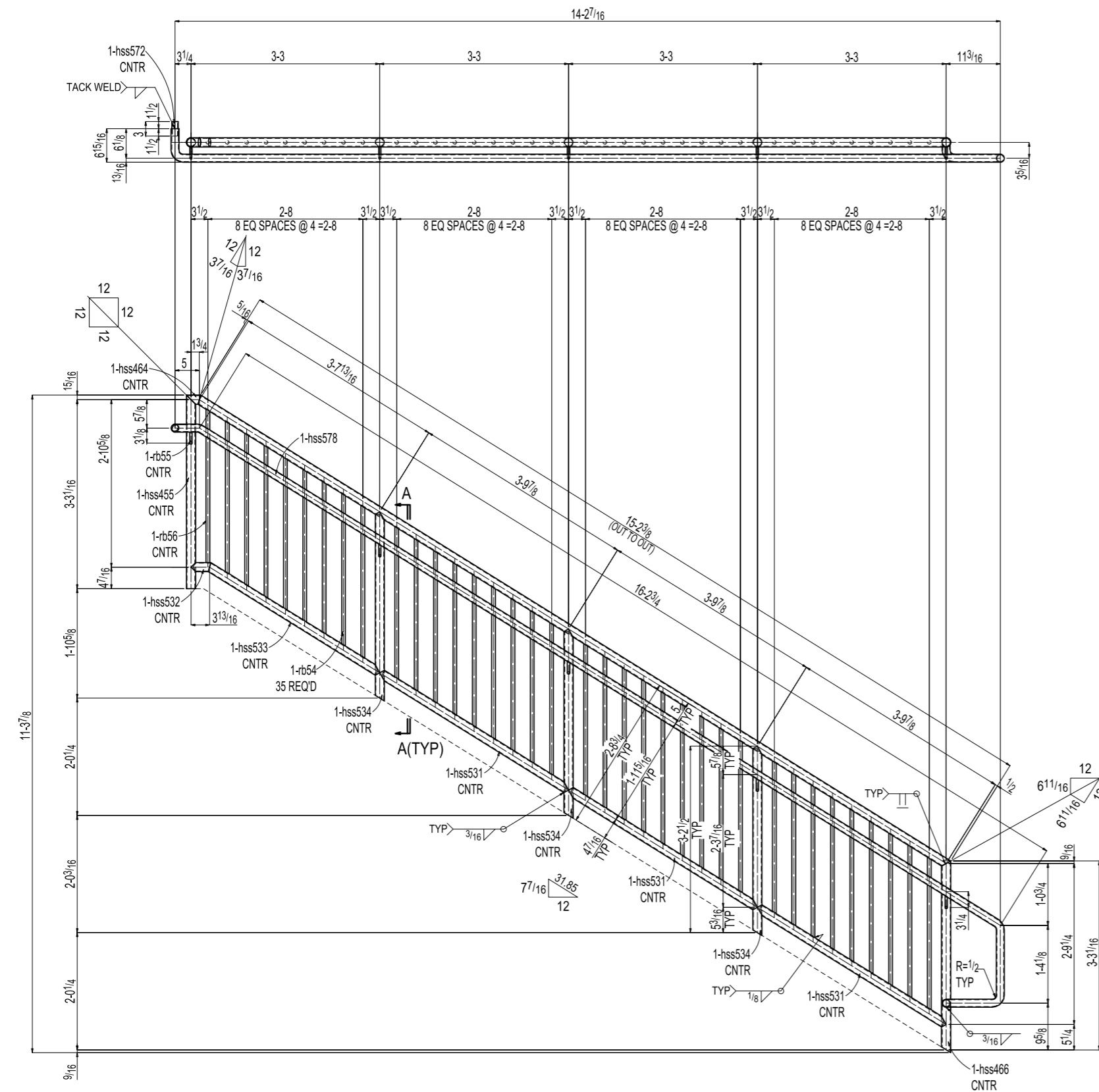

ONE HANDRAIL 4020HR1